

ICS 23.040.99; 25.220.60

English version

Steel tubes and fittings for onshore and offshore pipelines - Internal and external polyamide powder based coatings

Tubes en acier et raccords pour canalisations enterrées et immergées - Revêtements internes et externes à base de poudre polyamide

Stahlrohre und -formstücke für erd- und wasserlegte Rohrleitungen - Auskleidungen und Beschichtungen aus Polyamid-Pulver

This European Standard was approved by CEN on 20 February 2003.

CEN members are bound to comply with the CEN/CENELEC Internal Regulations which stipulate the conditions for giving this European Standard the status of a national standard without any alteration. Up-to-date lists and bibliographical references concerning such national standards may be obtained on application to the Management Centre or to any CEN member.

This European Standard exists in three official versions (English, French, German). A version in any other language made by translation under the responsibility of a CEN member into its own language and notified to the Management Centre has the same status as the official versions.

CEN members are the national standards bodies of Austria, Belgium, Czech Republic, Denmark, Finland, France, Germany, Greece, Hungary, Iceland, Ireland, Italy, Luxembourg, Malta, Netherlands, Norway, Portugal, Slovakia, Spain, Sweden, Switzerland and United Kingdom.



EUROPEAN COMMITTEE FOR STANDARDIZATION
COMITÉ EUROPÉEN DE NORMALISATION
EUROPÄISCHES KOMITEE FÜR NORMUNG

Management Centre: rue de Stassart, 36 B-1050 Brussels

Contents

1	Scope	5
2	Normative references	5
3	Terms and definitions.....	6
4	Symbols	6
5	Information to be supplied by the purchaser.....	6
5.1	Mandatory	6
5.2	Options indicated by the purchaser	7
6	Description of the coating.....	7
7	Application of the coating.....	7
7.1	Surface preparation	7
7.2	Primer application.....	8
7.3	Polyamide application	8
7.4	Coating fusion.....	8
8	Requirements of the applied coating.....	10
8.1	General.....	10
8.2	Appearance and continuity	10
8.3	Thickness of the coating system	10
8.4	Cut back at the tube ends	11
8.5	Holiday detection	11
8.6	Impact resistance.....	11
8.7	Adhesion.....	11
8.8	Indentation resistance.....	11
8.9	Electrical insulation resistance	12
8.10	Elongation at break.....	12
8.11	Resistance to ultraviolet radiation	12
8.12	Cathodic disbondment	12
8.13	Salt spray resistance	13
8.14	Demineralized water immersion	13
8.15	Flexibility.....	13
8.16	Waste water resistance	13
9	Repairs	13
10	Handling, transportation and storage.....	14
10.1	Handling.....	14
10.2	Transportation to storage areas.....	14
10.3	Storage.....	14
10.4	Loading of tubes and components for delivery.....	14
Annex A (normative) Holiday detection test.....		15
A.1	General.....	15
A.2	Apparatus	15
A.3	Procedure	15
A.4	Results	15
Annex B (normative) Adhesion test		16
B.1	General.....	16
B.2	Apparatus	16
B.3	Procedure	16
B.4	Results	16
Annex C (normative) Specific electrical insulation resistance test.....		18
C.1	General.....	18
C.2	Apparatus	18

C.3	Procedure	18
C.4	Results	18
Annex D (normative) Resistance to ultraviolet radiation		21
D.1	General.....	21
D.2	Apparatus	21
D.3	Procedure	21
D.4	Results	21
Annex E (normative) Cathodic disbondment test.....		23
E.1	General.....	23
E.2	Apparatus	23
E.3	Sampling.....	24
E.4	Procedure	24
E.5	Results	25
Annex F (normative) Demineralized water immersion test.....		29
F.1	General.....	29
F.2	Apparatus	29
F.3	Procedure	29
F.4	Results	29
Annex G (normative) Flexibility test.....		30
G.1	General.....	30
G.2	Apparatus	30
G.3	Procedure	31
Annex H (normative) Waste water resistance test.....		32
H.1	General.....	32
H.2	Apparatus	32
H.3	Procedure	32
H.4	Results	33
Annex I (normative) Viscosity analysis test		34
I.1	General.....	34
I.2	Equipment	34
I.3	Procedure	34
I.4	Results	35

Foreword

This document (EN 10310:2003) has been prepared by Technical Committee ECISS/TC 29 “Steel tubes and fittings for steel tubes”, the secretariat of which is held by UNI.

This European Standard shall be given the status of a national standard, either by publication of an identical text or by endorsement, at the latest by June 2004, and conflicting national standards shall be withdrawn at the latest by June 2004.

The annexes A, B, C, D, E, F, G, H and I are normative.

According to the CEN/CENELEC Internal Regulations, the national standards organizations of the following countries are bound to implement this European Standard: Austria, Belgium, Czech Republic, Denmark, Finland, France, Germany, Greece, Hungary, Iceland, Ireland, Italy, Luxembourg, Malta, Netherlands, Norway, Portugal, Slovakia, Spain, Sweden, Switzerland and the United Kingdom.

1 Scope

This European Standard defines the internal and/or external polyamide powder coatings applied by dipping in a fluidised bed or by spraying, or by roto-coating. These coatings are intended for the protection the inner and outer surfaces of steel tubes and their fittings (components) used as component parts of pipelines. This standard may also be applied for accessories, such as valves, pumps, screens, etc.

This type of coating is used for the protection of buried, submerged or above ground pipelines conveying fluids at working temperatures between 0 °C and + 60 °C. Other working service temperatures can be used after agreement between the purchaser and the coater.

The coatings covered by this standard are applicable to longitudinally or spirally welded steel tubes and to seamless steel tubes and their fittings components used for the construction of pipelines conveying liquids.

The internal coating of tubes to be used for the transportation of water intended for human consumption should not affect the quality of that water to such an extent that it fails to comply with the requirements of the EU and EFTA regulations.

For this purpose, reference should be made to the relevant national regulations and standards, transposing EN standards when available, dealing with the influence of materials on water quality and to the requirements for coatings.

NOTE A European Acceptance Scheme (EAS) is in course of development in relation to the CPD and the DWD. Its requirements will be introduced in this standard when completed.

2 Normative references

This European Standard incorporates by dated or undated reference, provisions from other publications. These normative references are cited at the appropriate places in the text, and the publications are listed hereafter. For dated references, subsequent amendments to or revisions of any of these publications apply to this European Standard only when incorporated in it by amendment or revision. For undated references the latest edition of the publication referred to applies (including amendments).

EN ISO 60, *Plastics – Determination of apparent density of material that can be poured from a specified funnel (ISO 60:1977)*.

EN ISO 62, *Plastics – Determination of water absorption (ISO 62:1999)*.

EN ISO 527-3, *Plastics – Determination of tensile properties – Part 3 : Test conditions for films and sheets (ISO 527-3:1995)*.

EN ISO 868, *Plastics and ebonite – Determination of indentation hardness by means of a durometer (shore hardness) (ISO 868:1995)*.

prEN ISO 1183-1¹⁾, *Plastics – Methods for determining the density of non-cellular plastics - Part 1 : Immersion method, liquid pyknometer method and titration method (ISO/DIS 1183-1:2002)*.

prEN ISO 1183-2¹⁾, *Plastics – Methods for determining the density of non-cellular plastics - Part 2 : Density gradient column method (ISO/DIS 1183-2:2002)*.

EN ISO 1183-3, *Plastics – Methods for determining the density of non-cellular plastics - Part 3 : Gas pyknometer method (ISO 1183-3:1999)*.

EN ISO 2808, *Paints and varnishes – Determination of film thickness (ISO 2808:1997)*.

1) To be published.

EN 10310:2003 (E)

EN ISO 3146, *Plastics - Determination of melting behaviour (melting temperature or melting range) of semi-crystalline polymers by capillary tube and polarizing-microscope methods (ISO 3146:2000).*

EN ISO 4287, *Geometrical product specification (GPS) – Surface texture : Profile method – Terms, definitions and surface texture parameters (ISO 4287:1997).*

EN ISO 4892-2, *Plastics – Methods of exposure to laboratory light sources – Part 2 : Xenon-arc sources (ISO 4892-2:1994).*

EN ISO 6272, *Paints and varnishes – Falling-weight test (ISO 6272:1993).*

EN ISO 7253, *Paints and varnishes – Determination of resistance to neutral salt spray (fog) (ISO 7253:1996).*

EN ISO 8501-1, *Preparation of steel substrates before application of paints and related products – Visual assessment of surface cleanliness – Part 1 : Rust grades and preparation grades of uncoated steel substrates and of steel substrates after overall removal of previous coatings (ISO 8501-1:1988).*

ISO 3105, *Glass capillary kinematic viscometers – Specifications and operating instructions.*

ISO 6441, *Paints and varnishes – Indentation test (spherical or pyramidal).*

3 Terms and definitions

For the purposes of this European Standard, the following terms and definitions apply.

3.1

coating manufacturer

supplier of the coating material in a condition suitable for application to the product to be coated

3.2

coater

company responsible for applying the coating material to the components to be coated

3.3

purchaser

company that buys the coated products

4 Symbols

R_z roughness parameter (the average surface roughness from five successive evaluation areas measured according to EN ISO 4287);

R_s specific electrical insulation resistance, expressed in ohms square metres ($\Omega \cdot m^2$);

k correction factor;

RT room temperature.

5 Information to be supplied by the purchaser

The following information shall be supplied to the coater by the purchaser.

5.1 Mandatory

In his enquiry and order the purchaser shall state the following minimum information:

- Identification of the tubes and components to be coated according to this European Standard. The designation shall include a reference to this standard and if applicable, a reference to the standard for the tube the coating has been applied to.;

Example : 5000 m of tube - EN 10224 of 406, 4-4, 0
External and/or internal coating – EN 10310;

- the nature of the fluid being conveyed.

5.2 Options indicated by the purchaser

If applicable, the following options may be specified by the purchaser:

- cut back length;
- chemical treatment;
- type and location of the marking;
- maximum area and number of repairs;
- maximum thickness of the coating.

6 Description of the coating

The coating system shall consist of a primer film overcoated with a layer of a fully fused polyamide powder coating.

7 Application of the coating

The polyamide coating shall be applied by dipping in a fluidised bed, spraying or roto-coating according to established procedures and the recommendations of the coating manufacturer.

The data sheets of the coating manufacturer shall contain the items required in Table 1.

7.1 Surface preparation

7.1.1 All tubes and components shall be abrasive blast cleaned. The degree of cleanliness shall be at least Sa 2_{1/2} as defined in EN ISO 8501-1.

7.1.2 Prior to abrasive blast cleaning, the steel surface shall be dry and free from contamination (oil, grease, temporary corrosion protection, etc.) and surface defects (slivers, laminations, etc.) detrimental to the surface or to the adhesion of the coating.

The blast-cleaned surface shall have a roughness R_z between 40 μm and 90 μm , when measured according to EN ISO 4287.

7.1.3 After abrasive blast cleaning, the surface of the tube or component shall be inspected and any slivers, laminations, weld spots and other surface imperfections that may have become visible shall be removed using suitable method..

After removal of these defects, the residual thickness of tubes and components shall satisfy the minimum tolerance requirements specified by the relevant standard. All treated areas greater than 10 cm^2 shall be prepared to provide a profile to satisfy the provisions of 7.1.2.

7.1.4 Prior to the application of the coating, the temperature of the tubes and components shall be maintained at least 3°C above the dew point.

7.1.5 Surface contaminants (e.g. residual abrasive dust) shall be removed prior to coating.

7.1.6 By agreement between the interested parties, chemical pre-treatment of the steel may be used in addition to abrasive blast cleaning

7.2 Primer application

Immediately after surface preparation, the primer coat shall be applied to give a dry film thickness that complies with the product technical data sheet (see Table 1).

7.3 Polyamide application

The coating system shall be completed by the application of polyamide powder coat.

7.4 Coating fusion

The polyamide coating may be applied to either on a hot or a cold substrate depending on the final thickness to be obtained.

7.4.1 Pre-heating

At the time of coating application, the temperature range on the steel surface shall comply with the coating manufacturer's recommendations.

The temperature of the steel component shall be monitored using a suitable means in order to ensure that the application conditions are being met.

The time the tube or component is held at temperature shall not result in oxidation of it's the steel surface, thermal damage of the primer coat or be detrimental to the quality and adhesion of the coating system.

7.4.2 Post-heating

After application of the polyamide layer to the substrate, post heating may be conducted. The fusion temperature and the temperature holding time shall be according to the coating manufacturer's recommendations and shall not be detrimental to the good quality and adhesion of the coating.

Table 1 — Content of data sheets

Items	Standard test reference	Layer 1 primer		Layer 2 polyamide
		Liquid	Powder	
Date of issue		+	+	+
Name of manufacturer		+	+	+
Name and type of product		+	+	+
Shelf life according to recommended storage condition		+	+	+
Pot-life at ambient temperature and mixing temperature		+		
Physical state of the delivered product		+	+	+
Type and size of container		+	+	+
Storage conditions		+	+	+
Colour		+		+
Method of application		+	+	+
Bulk density	EN ISO 60			+
Density	prEN ISO 1183-1, prEN ISO 1183-2 and EN ISO 1183-3			+
Solid by volume		+		
Solid by weight		+		
Particle size distribution				+
Viscosity	ISO 3105	+		+
Theoretical coverage per m ² per mm thickness		+		+
Processing temperature		+	+	+
Service temperature range of coating				+
Product preparation		+	+	+
Dry thickness range	EN ISO 2808	+	+	
Melting temperature	EN ISO 3146			+
Flash point		+		
Water absorption	EN ISO 62			+
Shore D hardness	EN ISO 868			+
Elongation at break	EN ISO 527-3			+
Impact resistance	EN ISO 6272			+
Adhesion test				+
Electrical insulation resistance				+
Safety data sheet reference		+	+	+

+ requires the specified information to be provided

8 Requirements of the applied coating

By agreement, at the time of enquiry and order, between the purchaser, the coater and the coating manufacturer the applied coating shall be checked against the following requirements.

8.1 General

The required properties of the applied coatings are given in Table 2. The electrical insulation resistance test and cathodic disbondment test apply to external coatings only; the other tests apply equally to internal and external coatings.

Table 2 — Properties of the applied coatings

Property	Coater			Coating manufacturer		
	0°C	RT	+ 60°C	0°C	RT	+ 60°C
Appearance and continuity of layer 2		+				
Thickness of the coating system		+				
Cut back length		+				
Holiday detection		+				
Impact resistance		+		+		
Adhesion		+		+		+
Indentation resistance					+	+
Electrical insulation resistance					+	
Elongation at break					+	
Resistance to ultraviolet radiation					+	
Cathodic disbondment					+	+
Salt spray resistance					+	
Demineralized water immersion					+	+
Flexibility				+	+	
Waste water resistance					+	
+ requires the specified information to be provided						

If other properties or working service temperatures (see clause 1) are required, alternative testing shall be agreed between the coater, the coating manufacturer and the purchaser.

The above properties are determined for the general usage of the coating in potable and waste water application. For other applications, the chemical resistance to the fluid to be conveyed shall be checked with the coating manufacturer.

8.2 Appearance and continuity

The appearance and continuity of the coating system shall be inspected visually over the whole surface of all the components.

The coating shall be of uniform colour, have a smooth appearance and be free of laminations.

8.3 Thickness of the coating system

The coating thickness shall be measured according to EN ISO 2808 – Method 6A.

Unless otherwise agreed by the purchaser, the absolute minimum thickness of the coating system at any point shall be 200 µm. On sharp edges where the radius of curvature is less than 3 mm, the minimum thickness shall not be less than 150 µm.

For components where sharp edges are an essential or unavoidable element of their design, a deviation from the minimum coating thickness is permissible subject to agreement by the purchaser.

A maximum coating thickness may be specified by the purchaser where appropriate to ensure mating tolerances (see 5.2).

8.4 Cut back at the tube ends

The length of the coating cut back, if required, shall be specified by the purchaser (see 5.2).

If coating has to be removed, the product surface shall not be damaged.

8.5 Holiday detection

Holiday detection shall be carried out according to the method defined in annex A.

For components with essential or unavoidable sharp edges (see 8.3), holiday detection is not required at the sharp edges.

Any holiday detected shall be repaired according to clause 9.

The final coating shall be free from holidays.

8.6 Impact resistance

The minimum impact energy, in joules, shall be determined according to EN ISO 6272 and shall correspond to $2,5 J \times k$ (k being the correction factor at any specified temperature (see Table 2)). The values of k to be used are given in Table 3.

Table 3 — Correction factor

Outside diameter D mm	k
$D > 219,1$	1,00
$76,1 < D \leq 219,1$	0,85
$D \leq 76,1$	0,70

After testing, the coating shall be free from holidays when checked according to annex A.

8.7 Adhesion

The adhesion shall be determined according to the requirement of annex B at any specified temperature (see Table 2).

The coating adhesion shall satisfy the requirement of rating 2 or better.

8.8 Indentation resistance

The indentation resistance shall be assessed by testing according to ISO 6441.

Testing shall be carried out using a penetrometer consisting of a spherical indenter and a weight. The indenter shall have a diameter of 1,8 mm (cross sectional area 2,5 mm²). The assembly, indenter plus weight, shall produce a force of 25 N and the test load shall be applied for 1 h.

The average indentation, measured to an accuracy of 0,01 mm, shall not be more than the values given in Table 4.

Table 4 — Indentation

Indentation at (23 ± 2)°C mm	Indentation at (60 ± 2)°C mm
0,05	0,1

8.9 Electrical insulation resistance

After being immersed in a 0,1 mol/l solution of sodium chloride for 100 days the specific electrical insulation resistance of the coating, R_s , shall be measured according to the method given in annex C,. The coating shall satisfy the following requirements:

- 1) the R_s value after 100 days immersion shall be not less than $10^8 \Omega \cdot m^2$;
- 2) when the R_s value after 70 days remains only one power of ten above the permissible value after 100 days, the ratio shall be satisfied : $\frac{R_s \text{ 100 days}}{R_s \text{ 70 days}} \geq 0,8$.

8.10 Elongation at break

This test shall be carried out according to EN ISO 527-3. The elongation at break shall not be less than 20 %.

8.11 Resistance to ultraviolet radiation

The test shall be carried out according to the method given in annex D.

When compared with unexposed coating, the exposed coating shall comply with the following requirements:

- an adhesion rating of 3 or better (see annex B);
- a reduction in viscosity (see annex I) not greater than 10 % of the original value.

8.12 Cathodic disbondment

This test shall be carried out according to the method given in annex E.

The extent of cathodic disbondment shall be the radial distance from the edge of the artificial defect to the edge of the coating that can be easily removed.

The average value of six such radial measurements shall not be greater than 7 mm and a single radial measurement shall not exceed 10 mm. Testing shall be carried out under the following conditions:

- 28 days at (23 ± 2)°C;
- 2 days at (60 ± 2)°C.

Other testing regimes may be used by agreement between the interested parties.

8.13 Salt spray resistance

This test shall be carried out according to EN ISO 7253.

Before exposure, an X cut shall be made through the coating on each coated sample according to annex B.

Testing shall be carried out for 1000 h and after exposure, the coating shall have an adhesion rating of 3 or better (see annex B).

8.14 Demineralized water immersion

This test shall be carried out according to the method given in annex F.

After immersion, an adhesion test according to the method given in annex B shall be carried out, the coating shall have an adhesion rating of 3 or better.

8.15 Flexibility

A test sample that has been prepared according to annex G, coated according to the recommendations of the coating manufacturer and is free from holidays (see annex A), shall be tested according to the method given in annex G.

After testing, the coating shall steel be free from holiday when checked at $(23 \pm 2)^\circ\text{C}$ and $(0 \pm 2)^\circ\text{C}$ according to annex A,.

8.16 Waste water resistance

This test shall be carried out according to the method given in annex H.

When compared with unexposed coating, the exposed coating shall comply with the following requirements:

- an adhesion rating of 3 or better (see annex B);
- a reduction in viscosity (see annex I).no greater than 10 % of the original value

9 Repairs

Components with localised defects (holidays, surface defects) and those that have been subjected to destructive testing may be repaired. The coating materials that may be used for repairing defects shall satisfy the following conditions:

- be suitable for the protection of onshore and offshore pipelines under the required service conditions (e.g. working temperature);
- be compatible in all respects with the polyamide powder coating already applied

The application conditions for the repair materials shall be those given in the manufacturer's technical data sheet or be agreed between the interested parties (manufacturers of the polyamide coating and the user of the material).

The completed repairs shall satisfy the performance values given in the manufacturer's technical data sheet and be free from holidays (see annex A). The thickness of the coating in the repaired areas shall not be less than the thickness of the original coating.

The maximum area and number of repairs that are permitted shall be agreed between the interested parties (see 5.2).

10 Handling, transportation and storage

10.1 Handling

Coated tubes and components shall be handled without causing damage to the ends of the tubes or to the coating. The direct use of steel ropes or slings or of any equipment that could damage the coating and tube ends is prohibited.

10.2 Transportation to storage areas

During transportation to storage areas at the coater's works, the coater shall take all relevant precautions to avoid damage to the tubes, components and to the coating.

10.3 Storage

During storage, precautions shall be taken to prevent deterioration of the coating. In particular, stacks of tubes and components that are intended to be stored for a long period shall be protected from the action of ultraviolet radiation.

10.4 Loading of tubes and components for delivery

During loading of tubes and components at the coater's factory, the coater shall take all relevant precautions to prevent damage to the coating.

Annex A (normative)

Holiday detection test

A.1 General

This test checks for porosity in the coating using a scanning electrode, energised by a high-voltage.

A.2 Apparatus

The apparatus shall consist of:

- an adjustable high-voltage holiday detector, equipped with a sound and/or light signal;
- a scanning electrode in the form of a metal brush, or conductive rubber conforming to the shape of the tube or component.

A.3 Procedure

The holiday detector shall be operated according to the instructions from its manufacturer.

Porosity in the coating shall be detected by a spark occurring between the steel surface of the tube or component and the electrode accompanied by a sound and/or light signal.

For the purposes of this test, the voltage shall be set at a value of 6 V per micron of nominal coating thickness and shall not exceed 25 kV.

The instrument shall be connected to the coated tube or component, switched on, and the electrode moved continuously across the surface of the coating to be inspected. The speed of the electrode shall be such that a defect of 1 mm in diameter can be detected.

A.4 Results

The number of holidays detected on each tube or component shall be recorded.

Annex B (normative)

Adhesion test

B.1 General

This test checks the adhesion of the coating by a destructive process.

B.2 Apparatus

The apparatus shall consist of:

- an utility knife with a stiff straight blade;
- a steel rule, if required;
- a steel rod, if required.

B.3 Procedure

B.3.1 The test area shall be any coated area on the tube or component or test piece that is free from all defects and of the correct dry film thickness.

B.3.2 Using a sharp-bladed utility knife, against a steel rule if required, straight 60 mm long cuts shall be made in the coating through to the metal surface to form an X with an angle of approximately 30° at the intersection point.

B.3.3 The point of the utility knife shall be inserted horizontally (that is, using the flat of the blade) under the coating at the intersection point of the 30° X-cuts such that the point of the blade is at the metal surface.

B.3.4 A levering action against a fulcrum (such as a steel rod) shall be used to force the flat point of the blade up from the metal surface in a single, vertical (i.e. at 90° to the surface) motion in an attempt to prise the coating off.

B.4 Results

The loss of coating adhesion, in millimetres, is measured from the intersection point on each X-cut to the nearest point where coating still adheres to the steel.

The adhesion is determined from the amount of adhesive failure between the coating and the steel. A limited amount of cohesive rupture within the coating shall be considered a pass provided there is still satisfactory adhesion.

The adhesion of the coating shall be assessed using the following ratings

- rating 1 : no removal of the coating other than that caused by insertion of the knife blade at the point of intersection (nominally less than 1 mm);
- rating 2 : not more than 2 mm of adhesion failure between the coating and the steel substrate;
- rating 3 : not more than 3 mm of adhesion failure between the coating and the steel substrate;
- rating 4 : not more than 4 mm of adhesion failure between the coating and the steel substrate ;

— rating 5 : not more than 5 mm of adhesion failure between the coating and the steel substrate.

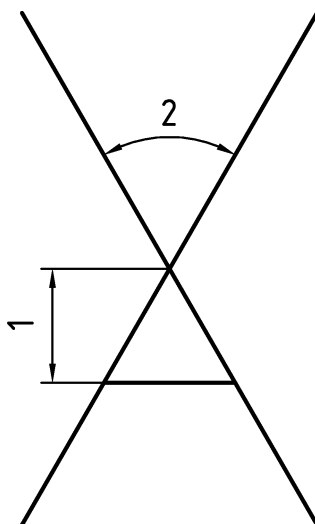
**Key**

- 1 Disbonded length
- 2 30°

Figure B.1 — Adhesion rating

Annex C (normative)

Specific electrical insulation resistance test

C.1 General

This test determines the specific electrical insulation resistance of the coating.

C.2 Apparatus

The apparatus shall consist of:

- a non metallic tank filled with 0,1 mol/l solution of sodium chloride made with demineralized water;
- an inert electrode made of copper;
- a direct current supply with a minimum voltage of 50 V;
- a suitable voltmeter and ammeter.

Other approved circuit testing equipment may be used.

C.3 Procedure

Testing shall be carried out at the temperature of $(23 \pm 2)^\circ\text{C}$ and shall be started a minimum of 24 h after the coating has been applied. If different test temperatures are required, the method described here shall be adapted after agreement between the coater and purchaser.

The test shall be conducted on a small diameter tube according to Figure C.1 or a large diameter tube according to Figure C.2. In each case the immersed test surface of the sample shall have an area of at least $0,03 \text{ m}^2$ that shall be measured and recorded.

At regular intervals from the third day of immersion and at least each week, the voltage U and the current I of the D.C. source shall be measured using the voltmeter and the ammeter. Specifically, measurements shall be taken on the 70th day and on the 100th day. At the time of the measurement, the positive pole of the current source shall be connected to the cylindrical section of the tube and the negative pole to the copper electrode, the minimum voltage of 50 V only being applied at the time of measurement.

The test shall be conducted for 100 days.

C.4 Results

The insulation resistance R_s , in ohms square metre ($\Omega \cdot \text{m}^2$), of the coating shall be calculated as follows:

$$R_s = \frac{U S}{I}$$

where :

S is the immersed area at the time of measurement, expressed in square metres (m^2);

U is the applied potential between the copper electrode and the steel piece of tube, expressed in volts (V);

I is the current passing between the copper electrode and the tube, expressed in amperes (A).

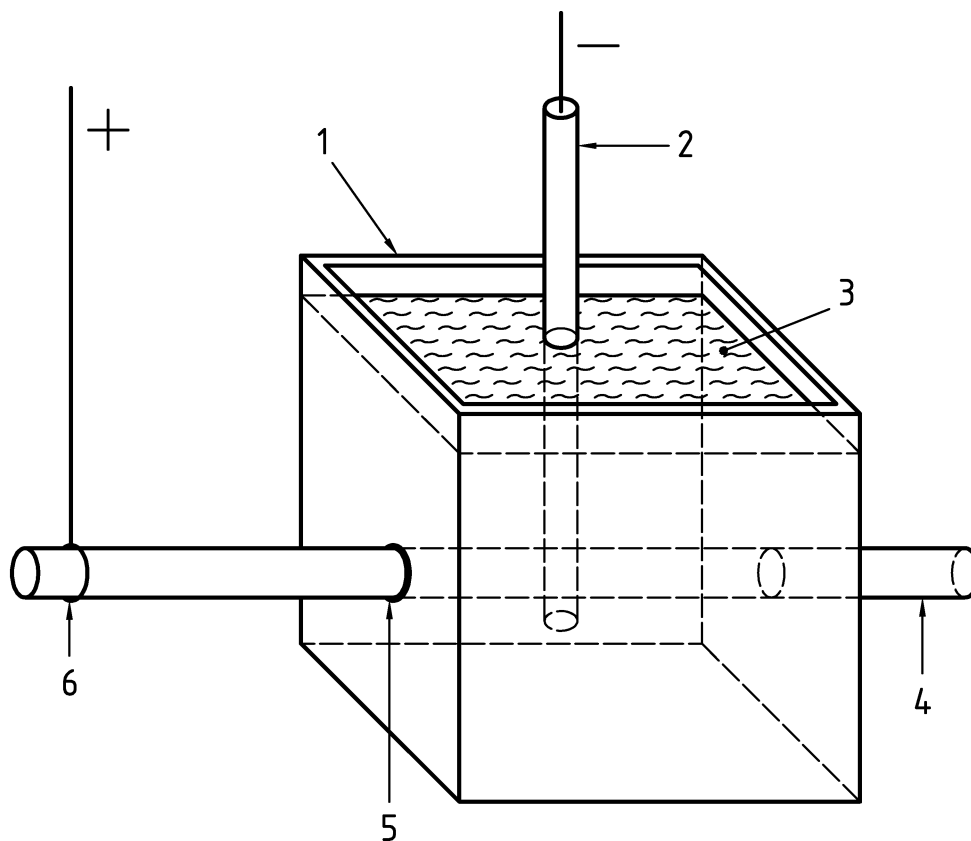

Key

- | | |
|---|------------------------------------|
| 1 Tank in insulating material | 4 Tube with anti-corrosion coating |
| 2 Copper electrode introduced only at the time of measurement | 5 Sealing |
| 3 NaCl solution | 6 Steel tube |

Figure C.1 — For small diameter tube

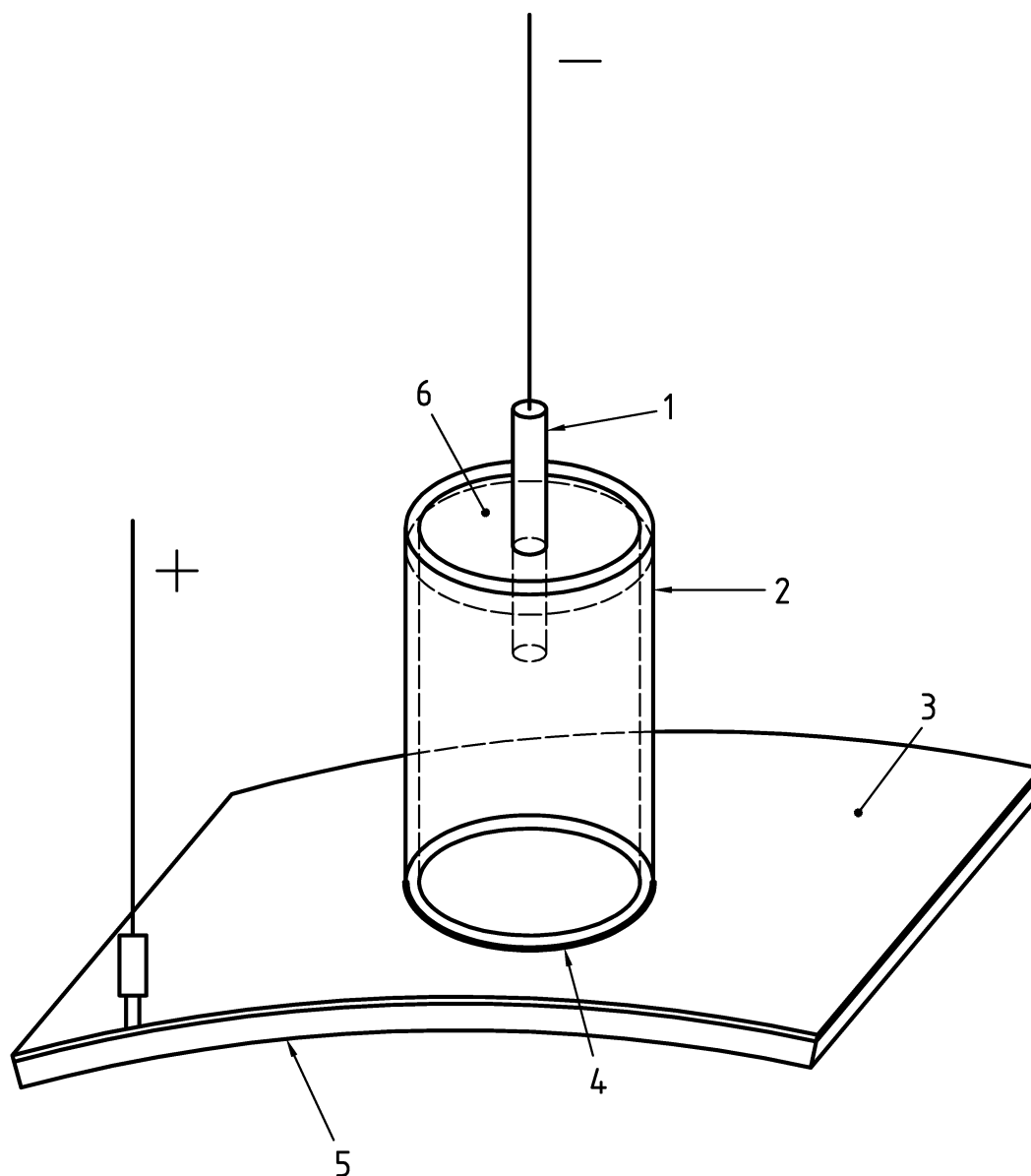

Key

- | | | | |
|---|---|---|---------------|
| 1 | Copper electrode introduced only at the time of measurement | 4 | Sealing |
| 2 | Tank in insulating material | 5 | Steel tube |
| 3 | Anti-corrosion coating | 6 | NaCl solution |

Figure C.2 — For large diameter tube

Annex D (normative)

Resistance to ultraviolet radiation

D.1 General

This test determines the ultraviolet radiation resistance of the coating.

D.2 Apparatus

Apparatus shall consist of:

- a weathering cabinet complying with EN ISO 4892-2;
- equipment as detailed in annex I.

D.3 Procedure

Three steel plates 150 mm x 75 mm, with a thickness equal to the component's thickness and coated under the same production conditions as the components, shall be provided for the test.

The samples shall be conditioned for 24 h, at $(23 \pm 2)^\circ\text{C}$ before testing.

The adhesion shall be measured according to annex B on one unexposed sample.

The viscosity shall be measured according to annex I on the same unexposed sample.

The remaining two samples shall be exposed to the weathering test according to the following alternate cycles:

- UV cycle: 4 h at 60°C ;
- condensation cycle: 4 h at 40°C and $(65 \pm 5)\%$ relative humidity.

The total exposure time shall be 1000 h.

After exposure, the following measurements shall be conducted:

- the coating adhesion according to annex B;
- the coating viscosity according to annex I.

D.4 Results

For each sample, the variation in coating adhesion and viscosity after 1000 h exposure shall be recorded together with the inspection and manufacturing dates.

The percentage variation in viscosity is calculated as follows:

$$\text{viscosity variation} = \frac{(V_1 - V_0)}{V_0} \times 100 \quad \%$$

where :

V_1 is the viscosity measured after exposure, expressed in seconds (s);

V_0 is the initial viscosity of the coating, expressed in seconds (s).

Annex E (normative)

Cathodic disbondment test

E.1 General

This test assesses the resistance of damaged coatings to loss of adhesion by disbondment when exposed to cathodic polarisation.

E.2 Apparatus

E.2.1 Electrical source

The source for the voltage and the current shall consist of a stabilised DC power unit²⁾. A cathodic polarisation potential of - 1500 mV to a saturated calomel reference electrode (equivalent to $U_H = - 1260$ mV where U_H is the potential of the standard hydrogen electrode) shall be maintained.

E.2.2 Electrolytic cell

For tests on large diameter tubes, a typical test cell configuration is shown in Figure E.1, whereas for small diameter tubes a typical test cell configuration is shown in Figure E.2.

The electrolytic cell shall comprise:

- a) a rigid plastic tube with an internal diameter of 50 mm, or a minimum of 10 mm diameter more than the maximum disbonded allowed from this standard;
- b) a rigid plastic cover in which holes shall be drilled to allow the passage of the electrodes and any other measuring instruments deemed necessary, and to allow the escape of hydrogen.

E.2.3 Electrodes

E.2.3.1 Reference electrode

The saturated calomel reference electrode or other suitable type of reference electrode to give an equivalent potential (see E.2.1) shall be placed in an electrode holder situated in a glass tube with a porous end plug. The end of this assembly shall be placed approximately 10 mm from the surface of the coating and approximately 20 mm from the coating defect.

The reference electrode used shall be suitable for the test temperature required.

E.2.3.2 Auxiliary electrode (anode)

The auxiliary electrode shall consist of an inert material, such as platinum wire of 0,8 mm diameter. It shall be immersed in the electrolyte³⁾.

The surface area of the anode shall be greater than the surface area of the cathode.

2) The current source should be capable of supplying 20 mA to each test area simultaneously.

3) To approximately 10 mm above the coating defect.

E.2.3.3 Working electrode (cathode)

The working electrode is represented by an artificial defect, which shall be 6 mm in diameter, with a maximum depth of 0,5 mm, in the steel substrate (see E.3.5 and Figure E.3).

E.2.4 Electrolyte

E.2.4.1 The electrolyte shall consist of a solution of 3% NaCl concentration in distilled or deionised water. The solution shall be made from analytical reagent grade sodium chloride.

E.2.4.2 During the test, the pH of the electrolyte at ambient temperature shall be in the range of 6 to 8,5.

E.2.4.3 The depth of the electrolyte in the cell shall be (75 ± 5) mm above the defect.

E.2.5 Test temperature

For test temperatures within the requirements of 8.12, the electrolyte shall not be cooled.

For test temperatures outside the requirements of 8.12, the test method shall be determined by agreement.

E.2.6 Heating equipment

Suitable heating equipment shall be used to establish and to maintain the test temperature of the sample.

If the sample is not heated in an oven, the temperature shall be checked on the artificial defect by an appropriate means, such as a temperature sensor.

E.3 Sampling

E.3.1 The test specimen shall be cold cut from a coated tube or fittings and shall have a minimum size of 80 mm x 80 mm. The test may also be performed on the body of the coated tube or fitting (see Figures E1 and E2).

E.3.2 Tests samples shall not be taken from the weld area.

E.3.3 For each sample, the thickness of the coating in the area subject to the test shall be measured and recorded.

E.3.4 The integrity of the coating on all test samples shall be checked using holiday detection (see annex A).

E.3.5 A 6 mm hole shall be drilled, through the coating, in the centre of the test specimen using a self-centring conical drill bit. The depth of the drilled hole in the steel substrate shall not exceed 0,5 mm. At the start of the test the total surface area subject to the test shall be free from residual coating.

E.3.6 The test area shall be degreased using a suitable solvent and then rinsed with potable water and subsequently dried.

E.4 Procedure

The plastic tube forming the electrolytic cell shall be sealed using a suitable sealant, e.g. a chemically inert adhesive. The artificial defect shall be in the centre of the cell.

During exposure, the voltage shall be maintained to $-(1500 \pm 50)$ mV.

After the test the cell with the electrolyte shall be removed. The test specimen shall be rinsed with water and dried.

After drying the area of the coating subjected to the test shall be examined according to the following procedure:

- the coated area around the defect shall be divided into six 60° segments and marked with radial lines cut through the coating to the steel with a sharp knife;
- disbondment shall be defined as the area of coating which is easily peeled from the steel substrate;
- for each of the 60° segments, the radial disbondment shall be measured from the edge of the artificial defect to the edge of the disbonded area of the coating.

E.5 Results

The result of the cathodic disbondment test is defined as the arithmetic mean of the six single values for the radial length and shall be rounded to the nearest full millimetre.

The maximum value of disbondment shall be recorded.

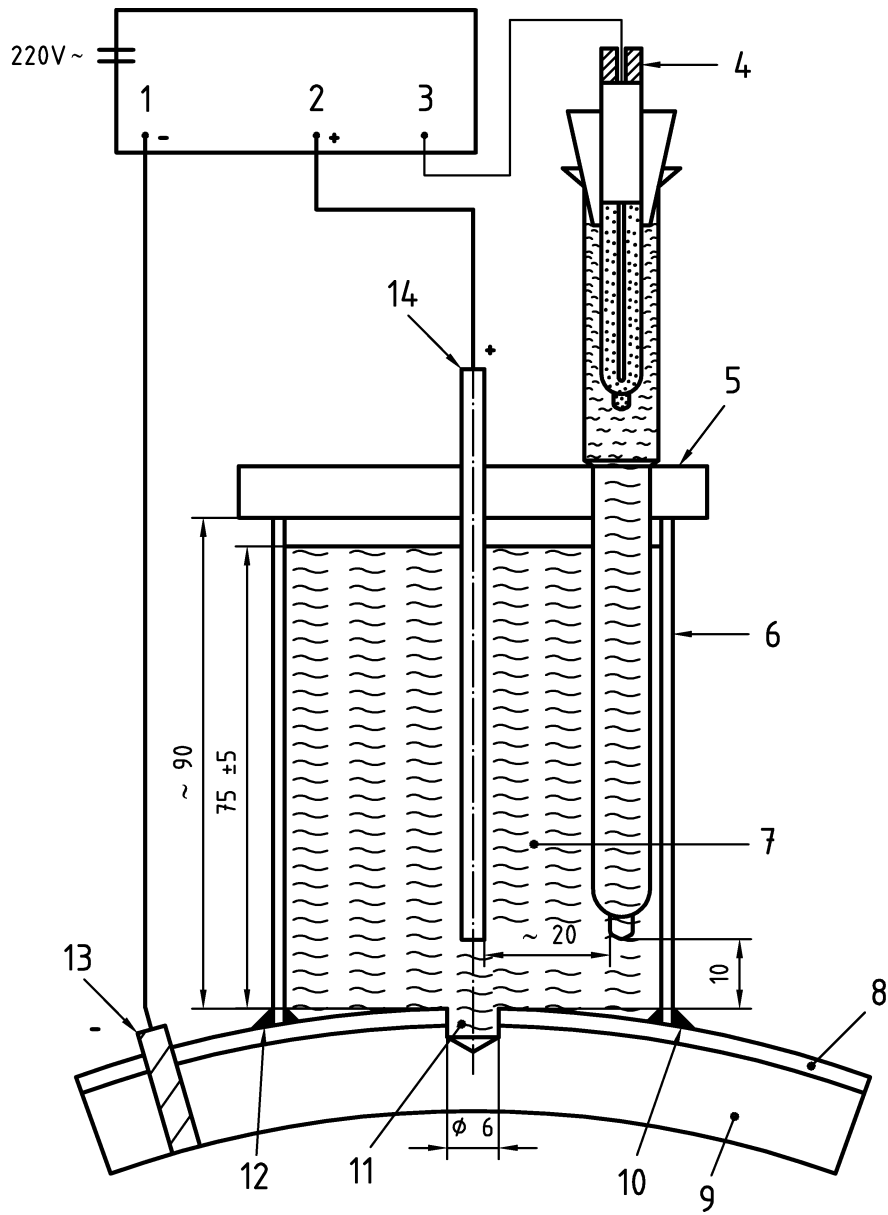

Key

- | | |
|--|--|
| 1 Working electrode | 8 Coating |
| 2 Electrode (anode) | 9 Steel test piece |
| 3 Electrode (reference) | 10 Sealing material |
| 4 Saturated calomel reference electrode | 11 Artificial defect |
| 5 Plastic cover | 12 Sealing material |
| 6 Plastic tube, minimum internal \varnothing 50 mm | 13 Electrode (cathode) |
| 7 Electrolyte \geq 150 ml | 14 Platinum electrode \varnothing 0,8 mm to 1,0 mm (anode) |

Figure E.1 — Electrolytic cell for large diameter tube

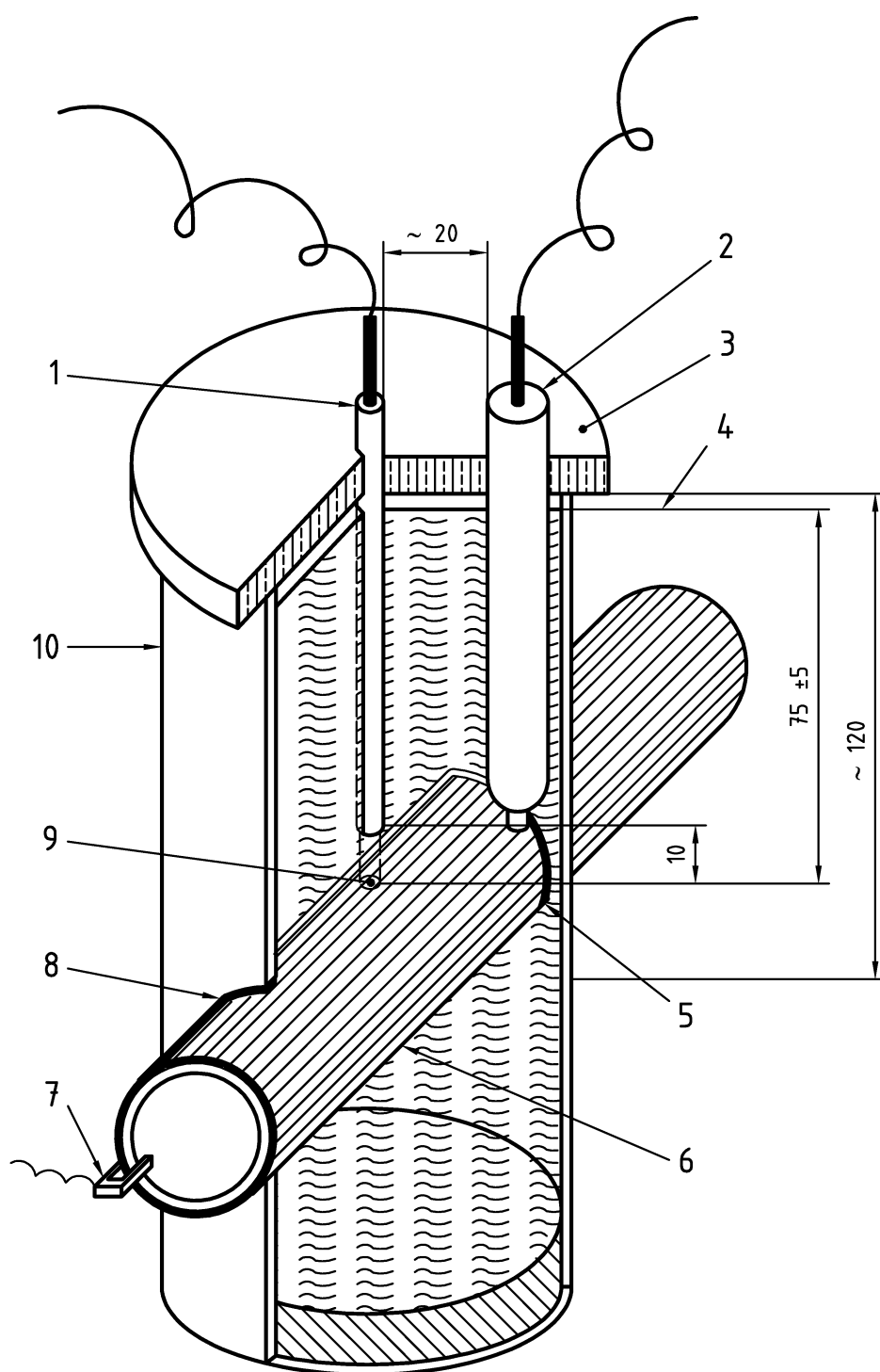

Key

- | | | | |
|---|---|----|--|
| 1 | Platinum electrode \varnothing 0,8 mm to 1,0 mm (anode) | 6 | Coated tube |
| 2 | Saturated calomel reference electrode | 7 | Working electrode (cathode) |
| 3 | Plastic cover | 8 | Sealing material |
| 4 | Electrolyte level | 9 | Artificial defect \varnothing 6 mm |
| 5 | Sealing material | 10 | Plastic tube, minimum internal \varnothing 50 mm |

Figure E.2 — Electrolytic cell for small diameter tube

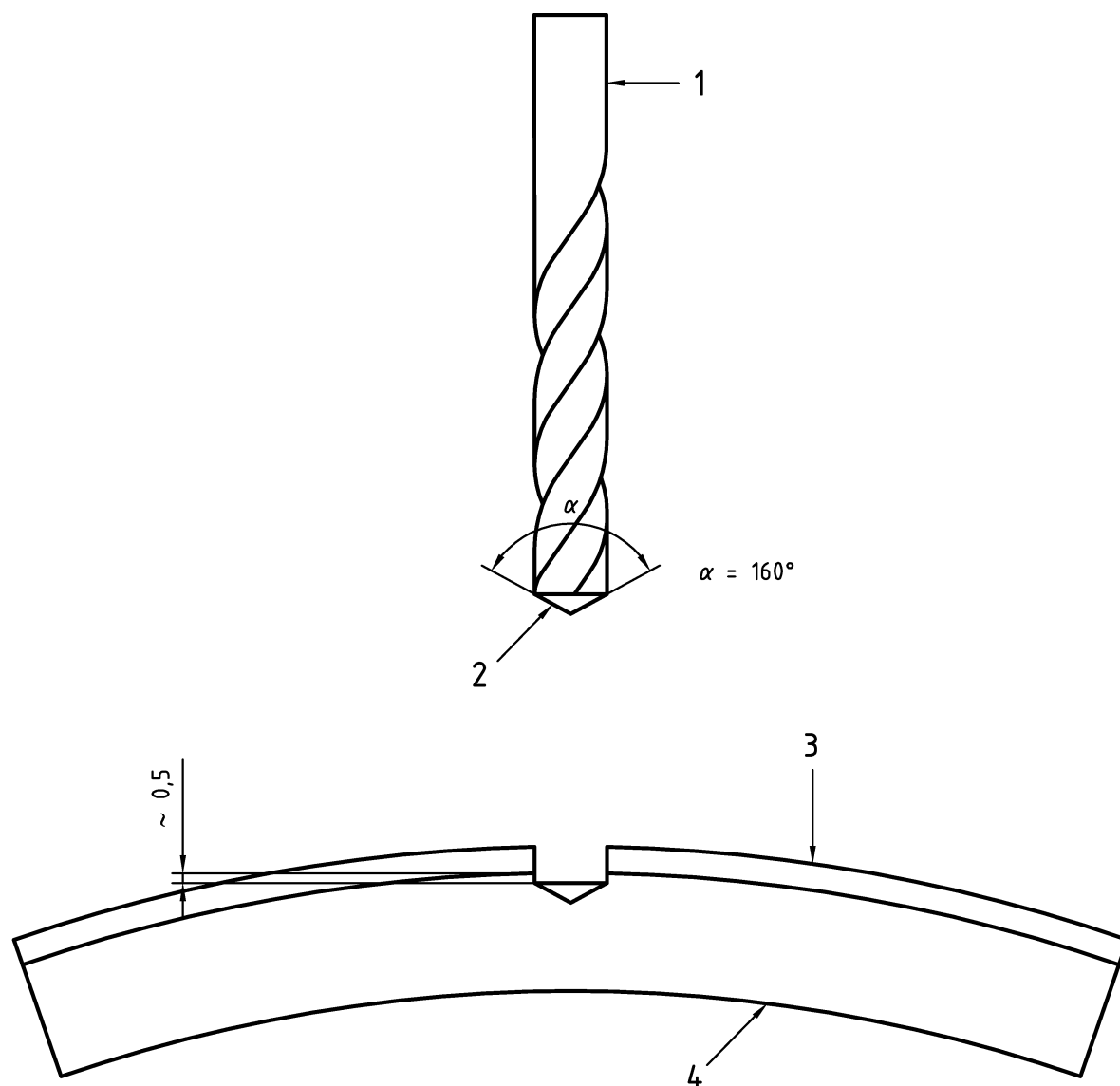

Key

- 1 Fluted and mill face \varnothing 6 mm
- 2 Conic end
- 3 Coating
- 4 Steel

Figure E.3 — Production of artificial defect

Annex F (normative)

Demineralized water immersion test

F.1 General

This test assesses the resistance of the coating to the action of demineralized water.

F.2 Apparatus

A stirred water bath, at least 300 mm deep, is required.

F.3 Procedure

The test shall be carried out on two steel plates (150 mm x 100 mm x 3 mm) coated to the correct thickness (see 8.3) and free from all defects at the specified temperatures (see Table 2).

The plates shall not be tested within 24 h after coating; the plates shall then be immersed for 90 days.

After immersion, the plates shall be left for 24 h at room temperature

After exposure, 3 measurements of the coating adhesion shall be made on each plate according to annex B.

F.4 Results

The adhesion rating measured according to annex B shall be recorded.

Annex G (normative)

Flexibility test

G.1 General

The test determines the flexibility of the coating.

G.2 Apparatus

The test apparatus shall consist of:

- a bending machine consisting of a circular section mandrel and a support for test plates;
- a refrigerator (for the low temperature test).

G.2.1 Mandrel

The mandrel shall have a radius of 100 mm.

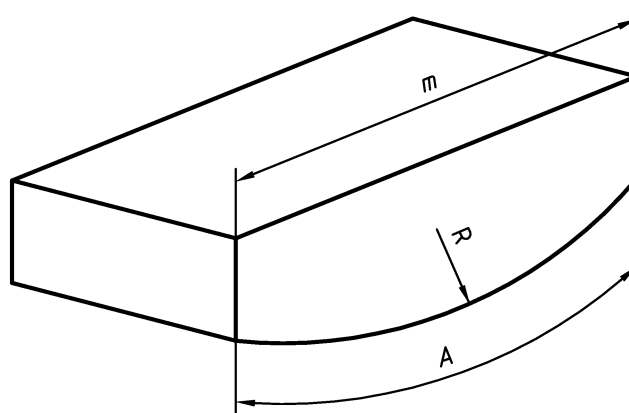

Key

- A Arc length ($A = (225 \pm 25)$ mm)
R Radius of mandrel (100 mm)
m Chord length

Figure G.1 — Mandrel

G.2.2 Support gap

The arc length of the mandrel shall be fixed at (225 ± 25) mm.

The panel support gap shall be set according to the following formula:

$$\text{Support gap} = (m + 16) \text{ mm}$$

where:

m is the chord length across the mandrel arc, expressed in millimetres (mm).

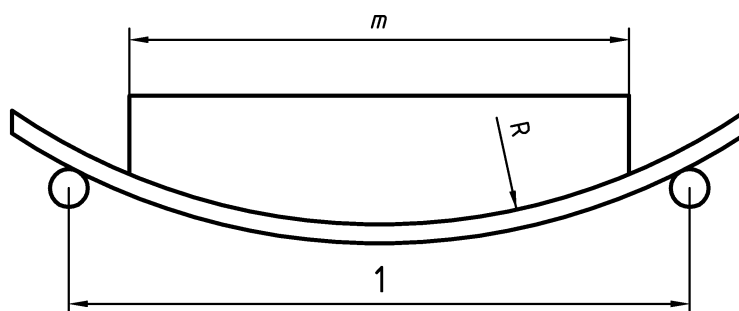

Key

1 Support gap = $m + 16$ mm

Figure G.2 — Flexion support

G.3 Procedure

The test shall be carried out on steel plates 50 mm x 300 mm x 6 mm coated to the correct thickness (see 8.3) and free from all defects.

The bending shall be conducted at a maximum deflection rate of 25 mm/min over the appropriate mandrel at the specified temperatures (see Table 2).

The panel shall be bent until it makes contact with the whole surface of the mandrel.

During bending, peaking (point at which a gap occurs between the mandrel and the panel) may be observed at the centre of the panel. In this case, the area of the panel where the gap exceeds 0,25 mm shall be disregarded in evaluating the test results. This area shall not exceed 25 % of the mandrel area.

The plates shall be examined immediately after bending and after 24 h at $(23 \pm 2)^\circ\text{C}$.

Annex H (normative)

Waste water resistance test

H.1 General

This test assesses the resistance of the coating to waste water.

H.2 Apparatus

The test apparatus shall consist of:

- a water bath with stirrers, at least 300 mm deep;
- an apparatus complying with annex B, for measuring coating adhesion;
- an apparatus complying with annex I, for measuring viscosity;
- effluent with composition as shown in Table H.1.

H.3 Procedure

Three steel plates 150 mm x 75 mm, with a thickness equal to the component's thickness and coated under the same production conditions as the components, shall be provided for the test.

The samples shall be conditioned for 24 h, at $(23 \pm 2)^\circ\text{C}$ before testing.

The adhesion shall be measured according to annex B on one unexposed sample.

The viscosity shall be measured according to annex I on the same unexposed sample.

The remaining two samples shall be exposed to the waste water at a temperature of $(23 \pm 3)^\circ\text{C}$ for a period of 30 days.

The composition of the waste water shall be as shown in Table H.1.

Table H.1 — Composition of the waste water

Constituents	mg/l
Starch	50
Sodium stearate	32
Sodium acetate	56
Glycerine tri-stearate	15
Urea	13
Ammonium sulphate	70
Proteins	90
Potable water	balance

At the end of immersion period, the test plates shall be rinsed with demineralized water and be allowed to dry for 24 h at a temperature of $(23 \pm 3) ^\circ\text{C}$.

After 24 h, the adhesion (see annex B) and the viscosity (see annex I) of the coating shall be measured.

H.4 Results

The adhesion rating measured according to annex B and the viscosity measured according to annex I shall be recorded.

Annex I (normative)

Viscosity analysis test

I.1 General

This test determines the dilute solution viscosity of the polyamide.

The viscosity of the polyamide is carried out by measuring the rate of flow, in seconds, through a capillary tube.

I.2 Equipment

The following equipment is used for this test:

- a viscometer equipped with a chronometric average to 0,01 of a second;
- a precision balance;
- a drying oven/incubator;
- a dryer/desiccator and a crystalliser;
- an Ubbelohde viscometer complying with ISO 3105.

I.3 Procedure

The test is carried out on polyamide coating taken directly from a test piece. A minimum of 75 mg weight of polymer shall be removed from the applied coating. The polyamide sample shall be dissolved in the meta-cresol ($\text{CH}_3\text{C}_6\text{H}_4\text{OH}$), to give a concentration of 5 g/l at $(23 \pm 2)^\circ\text{C}$.

I.3.1 Preparation of the sample

The sample shall be prepared using the following stages :

- drying: the sample is placed in a large diameter crystalliser which is then placed in an oven at a temperature of 80°C for 90 min and cooled in a dryer/desiccator for at least 15 min ;
- dissolving: dissolve the polyamide in sufficient meta-cresol to give a concentration of 5 g/l solution.

I.3.2 Measurement of the viscosity

I.3.2.1 Flow rate of the metacresol

The time in seconds for a given volume of the meta-cresol to flow through the measuring capillary.

I.3.2.2 Flow rate of the solution

The time in seconds for a given volume of the solution prepared according to I.3.1 to flow through the measuring capillary.

I.4 Results

The viscosity of the polyamide is given in litres per gram according to the formula:

$$\eta_{\text{inh}} = \left(\frac{1}{C} \right) \ln \left(\frac{t'}{t} \right)$$

where :

η_{inh} is the inherent viscosity of the product, expressed in litres per gram;

C is the concentration in grams per litre;

t' is the flow rate of the solution, expressed, in seconds;

t is the flow rate of the meta-cresol solution, expressed in seconds.

NOTE The meta-cresol should be dehydrated by distillation and stocked in 2 l stoppered bottles. Each bottle should be marked before use with a measure of viscosity expressed in l/g, which should be approximately 19,3 and calculated according to the formula:

$$= K d_{20} t$$

where :

K is the constant of the viscosimeter tube ;

d_{20} is the density of the meta-cresol at $(23 \pm 2) ^\circ\text{C}$ (1034) ;

t is the flow rate, expressed in seconds.